

CHAMBRES POUR OUVRAGES  
SOUTERRAINS DE RESEAUX SECS

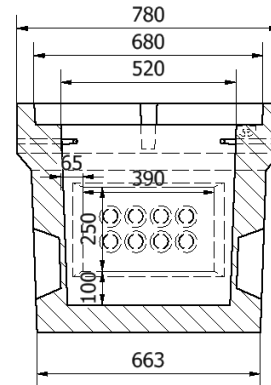
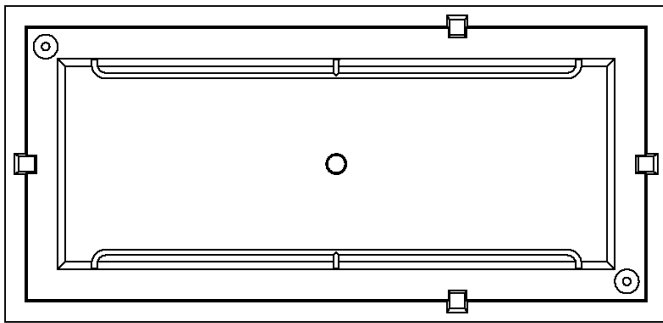
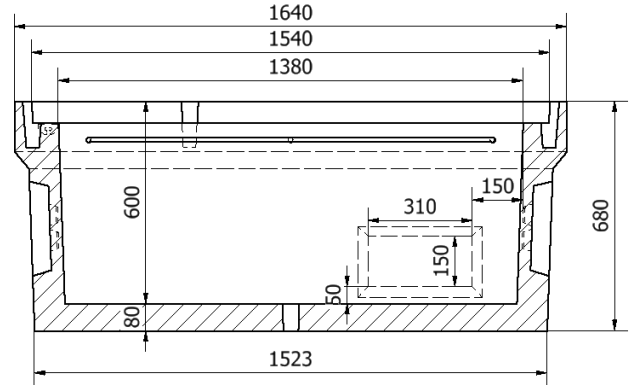

### Caractéristiques :

- Poids maximum : 696 kg
- Longueur minimale d'élingage : 155 cm
- Manutention par 2 ancrs de levage 1T3

### Usine de fabrication

	Champagné (72)	Chenon (16)	Luçon (85)	Portet (31)
Réf. article		FAB00345	FAB02486	FAB01716



ANGLE D'ÉLINGAGE  
MAXI 60°



TRANSPORT PAR LE  
CLOU INTERDIT

DÉFENSE DE PASSER SOUS LA CHARGE

