

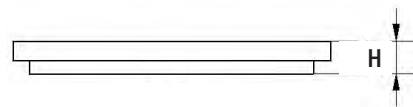

Couvercle

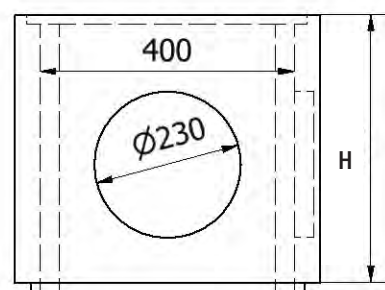

Réhausse

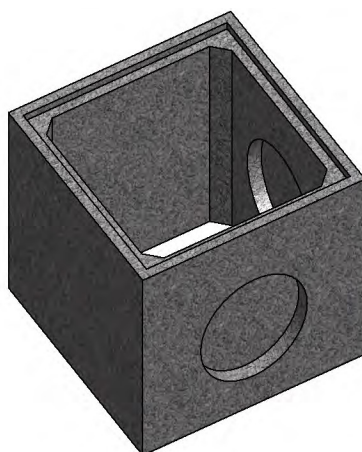

Élément de fond

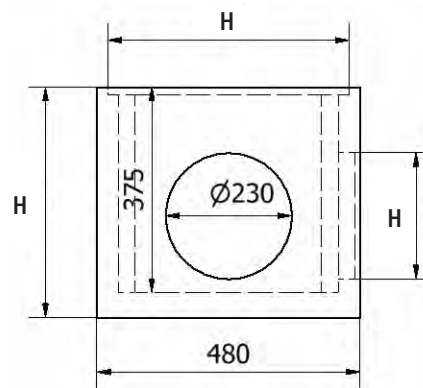
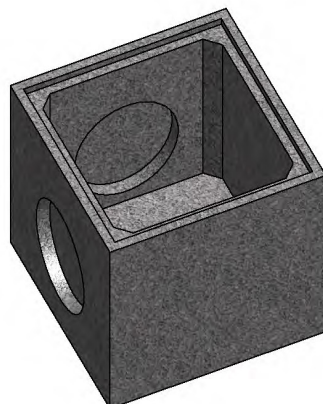

Caractéristiques :

- 3 voiles à briser (2 extérieurs et 1 intérieur)

	Hauteur (mm)	Réf. article	Poids (kg)
Fond	420	FAB00803	88
Réhausse	200	FAB01000	36
	400	FAB01001	68
Couvercle	50	FAB00368	25

Fabrication usine de Chenon (16)